

SYSTÈME D'ÉCHAFAUDAGE

418-626-9122

888-738-9122



Service de remorque gratuit

C32

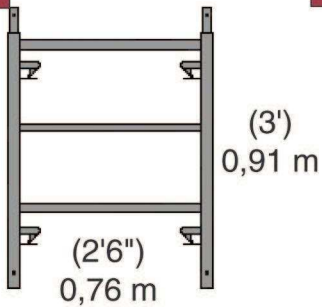

Poids: 8,16 kg (18 lbs)

C34

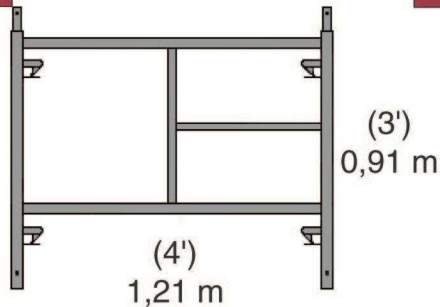

Poids: 10,43 kg (23 lbs)

C35

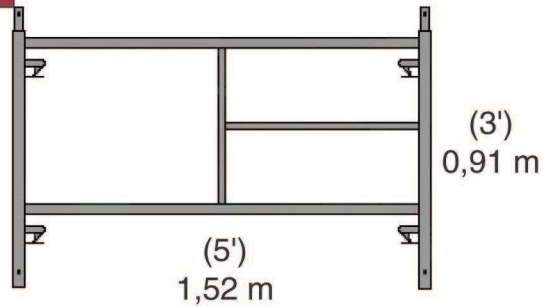

Poids: 13,6 kg (30 lbs)

C517

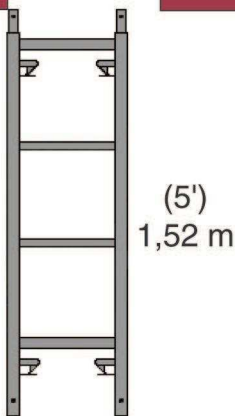

Poids: 9,52 kg (21 lbs)

Pour espace restreint et réservoir pétrolier

C52

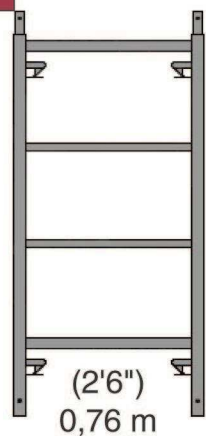

Poids: 12,7 kg (28 lbs)

C54

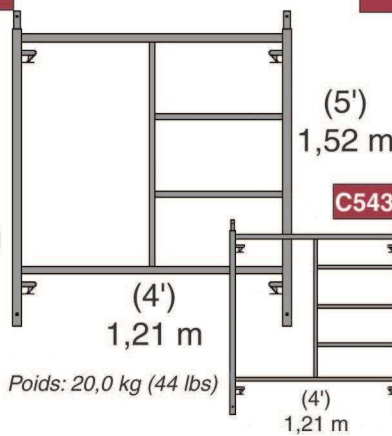

Poids: 20,0 kg (44 lbs)

Poids: 18,6 kg (41 lbs)

C55

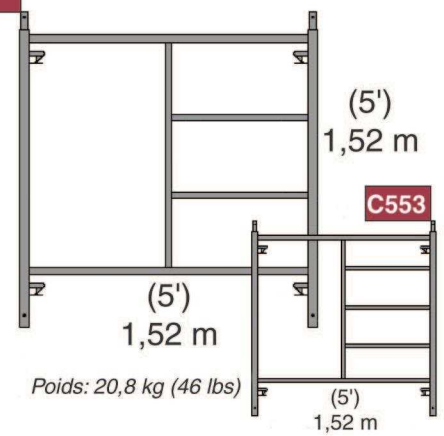

Poids: 20,8 kg (46 lbs)

Poids: 19,95 kg (44 lbs)

C105

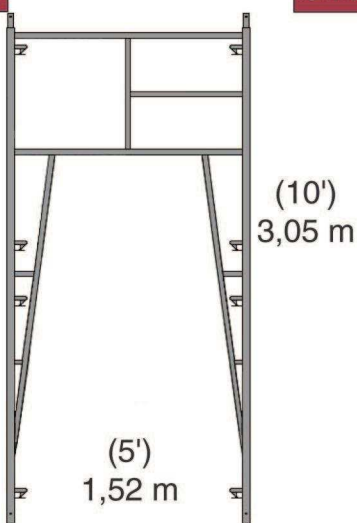

Poids: 38,6 kg (85 lbs)

Pour contrer les obstacles ou pour passage piétonnier (C.S. art.2.7.2)

C107

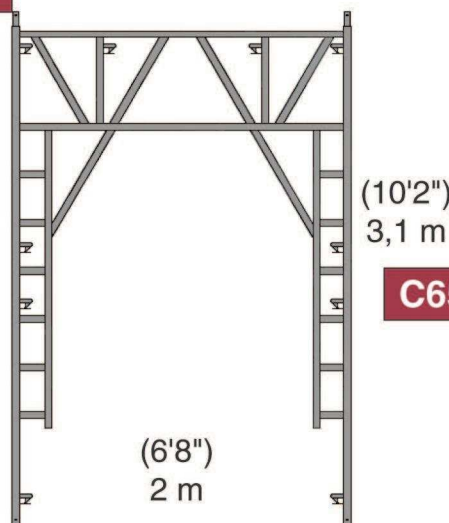

Poids: 116 lbs

Pour passage piétonnier (C.S. art.2.7.2)

C62

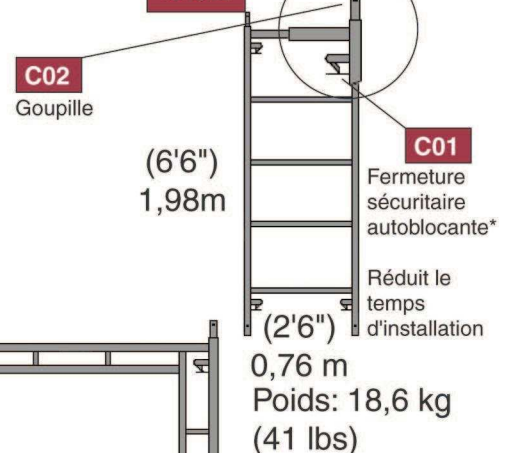

C02
Goupille

C01
Fermeture sécuritaire autoblocante*

Réduit le temps d'installation

Poids: 18,6 kg (41 lbs)

C65

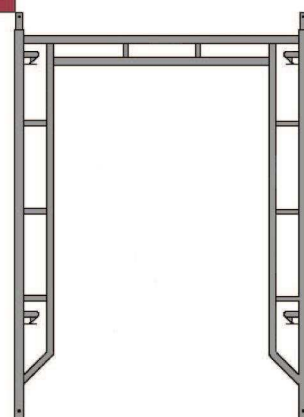

* Fermeture sécuritaire autoblocante (brevet #767004) sur tous nos échafaudages.

Spécifications:

1. Échafaudages fabriqués avec des tubes d'acier à haute teneur en carbone.
2. Espace de 15" entre les barreaux; sauf pour C543 et C553, hauteur 12"

EXEMPLE D'UN SYSTÈME D'ÉCHAFAUDAGE

